



Cerniere·Catenaacci

- 
-  Hinges - Bolts
 -  Scharniere - Riegel
 -  Charnières - Verrous
 -  Bisagras - Cerrojos

Cerniera in ferro a saldare a 2 ali chiuse con perno sfilabile grezza

- Black iron 2-closed wing hinge with removable pin to be welded
- Schwarze Eisen Scharniere 2-geschloss. Fluegel mit ausziehbar. Stifte zum schweißen
- Charnière fer brut 2 volets fermés pivot dégonnable à souder
- Bisagra hierro negro 2 alas cerradas con pernio extraíble

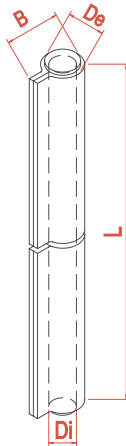

ARTICOLO - ARTICLE		L	B	De	Di	EG		€
Riferimento-Reference		mm				N°	EG	x1
133/60	EG 00 60 20	60	13	9.5	6	24	0.9	0,44
133/80	EG 00 80 20	80	16.5	12	8	24	1.8	0,50
133/100	EG 00 10 20	100	18	13.5	8.5	24	2.8	0,60
133/120	EG 00 12 20	120	19.5	15	10	24	4.3	0,60
133/140	EG 00 14 20	140	22	16.5	10.5	24	5.8	0,90
133/170	EG 00 17 20	170	23.5	17.5	12	12	4.2	1,60
133/200	EG 00 20 20	200	27	20	14	12	6.6	2,00

Cerniera in ferro a saldare a 2 ali chiuse c/perno fisso c/tappo grezza

- Black iron 2-closed wing plug hinge with fixed pin to be welded
- Schwarze Eisen Scharniere 2 geschlossen. Fluegel mit fest. Stifte zum schweißen
- Charnière fer brut 2 volets fermés avec bouchon pivot fixe à souder
- Bisagra hierro negro 2 alas cerradas con pernio fijo para soldar

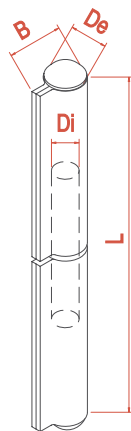

ARTICOLO - ARTICLE		L	B	De	Di	EG		€
Riferimento-Reference		mm				N°	EG	x1
134/60	EG 00 60 21	60	17	12	8	24	1.2	0,60
134/80	EG 00 80 21	80	17	12	8	24	1.5	0,70
134/100	EG 00 10 21	100	19	13.5	9	24	2.3	0,80
134/120	EG 00 12 21	120	20	14.5	10	24	2.9	1,20
134/140	EG 00 14 21	140	21	16	11	24	4.1	1,40
134/170	EG 00 17 21	170	23.5	17	12	12	2.9	2,20
134/200	EG 00 20 21	200	26.5	20	14	12	4.6	2,70

Cerniera in ferro a saldare a 3 ali chiuse c/perno sfilabile grezza



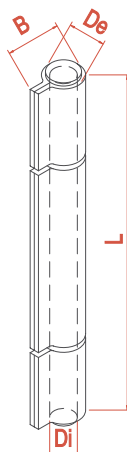

- Black iron 3-closed wing hinge with removable pin to be welded
- Schwarze Eisen Scharniere 3 geschlossen. Fluegel mit ausziehbar. Stifte zum schweißen
- Charnière fer brut 3 volets fermés pivot dégonnable à souder
- Bisagra hierro negro 3 alas cerradas con pernio extraíble para soldar







ARTICOLO - ARTICLE		L	B	De	Di	EG		€
Riferimento-Reference		mm				N°	EG	x1
135/80	EG 00 80 30	80	16.5	12	8	24	1.8	0,50
135/100	EG 00 10 30	100	18	13.5	8.5	24	2.7	0,70
135/120	EG 00 12 30	120	19.5	15	10	24	4.2	0,80
135/140	EG 00 14 30	140	22	16.5	10.5	24	5.7	1,00
135/170	EG 00 17 30	170	23.5	17.5	12	24	4.2	1,70
135/200	EG 00 20 30	200	27	20	14	12	6.6	2,20

Cerniere·CatenaCci

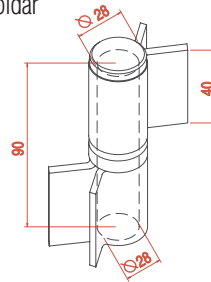



Cerniera in ferro a saldare grezza a 2 ali aperte c/perno sfilabile con rondella

-  Black iron 2 open wing hinge with removable pin and ring to be welded
-  Schwarze Eisen Scharniere 2 offen. Fluegel mit ausziehbar. Stifte und Ring zum schweiessen
-  Charnière fer brut 2 volets ouverts pivot dégonflable à souder
-  Bisagra hierro negro 2 alas abiertas con pernio extraible y anilla de seguridad para soldar







ARTICOLO - ARTICLE				
Riferimento-Reference	N°		x1	
136	EG 00 90 20	8	4.2	3,50

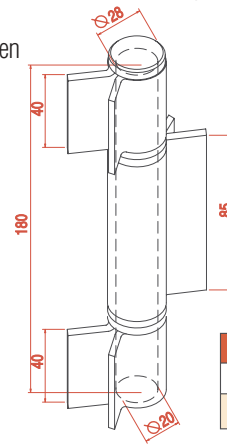



Cerniera in ferro a saldare grezza a 3 ali aperte c/perno sfilabile con rondella grezza

-  Black iron 3 open wing hinge with removable pin and ring to be welded
-  Schwarze Eisen Scharniere 3 offen. Fluegel mit ausziehbar. Stifte und Ring zum schweiessen
-  Charnière fer brut 3 volets ouverts pivot dégonflable a souder
-  Bisagra hierro negro 3 alas abiertas con pernio extraible y anilla para soldar







ARTICOLO - ARTICLE				
Riferimento-Reference	N°		x1	
137	EG 00 18 30	4	4.2	5,70

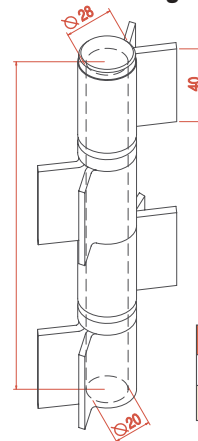



Cerniera in ferro a saldare grezza a 4 ali aperte c/perno sfilabile con rondella grezza

-  Black iron 4 open wing hinge with removable pin and ring to be welded
-  Schwarze Eisen Scharniere 4 offen. Fluegel mit ausziehbar. Stifte und Ring zum schweiessen
-  Charnière fer brut 4 volets ouverts pivot dégonflable à souder
-  Bisagra hierro negro 4 alas abiertas con pernio extraible y anilla para soldar







ARTICOLO - ARTICLE				
Riferimento-Reference	N°		x1	
138	EG 00 18 40	4	4.2	7,00

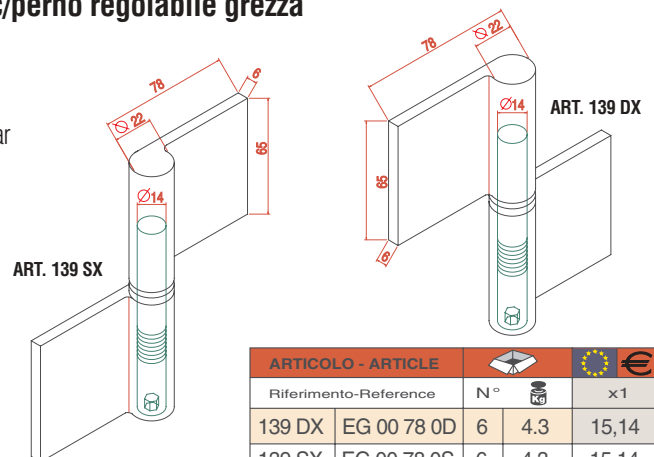



Cerniera in ferro per porte blindate a saldare grezza a 2 ali c/perno regolabile grezza

-  Black iron 2 wing hinge for security door w/adjustable pin to be welded
-  Schwarze Eisen Scharniere 2 Flueg. mit regel. Stifte fuer Sicherheitstuer
-  Charnière fer brut à souder pour porte blindée a 2 volets + regulat.
-  Bisagra hierro negro 2 alas+pernio regulable+cojinete para puerta blindada para soldar





ARTICOLO - ARTICLE				
Riferimento-Reference	N°		x1	
139 DX	EG 00 78 0D	6	4.3	15,14
139 SX	EG 00 78 0S	6	4.3	15,14



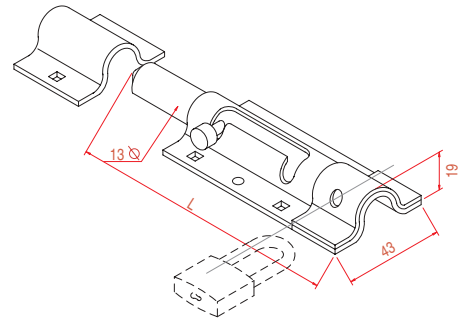

Catenaccio ad avvitare asta tonda pesante con portalucchetto

-  Barrel bolt for padlock heavy duty to be screwed
-  Riegel zum einschrauben fuer Vorhaengeschoß
-  Verrou rond à visser avec porte cadenas modèle lourd
-  Cerrojo a atornillar con barra redonda pesada para candado





ARTICOLO - ARTICLE		L			€
Riferimento-Reference			N°	kg	x1
110/150	AT 43 15 13	150	10	3.2	4,40
110/200	AT 43 20 13	200	10	4.1	5,20
110/250	AT 43 25 13	250	10	5.1	5,80



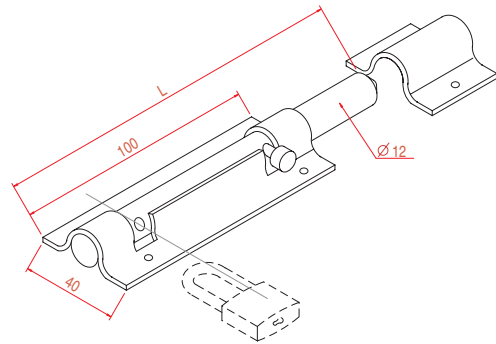
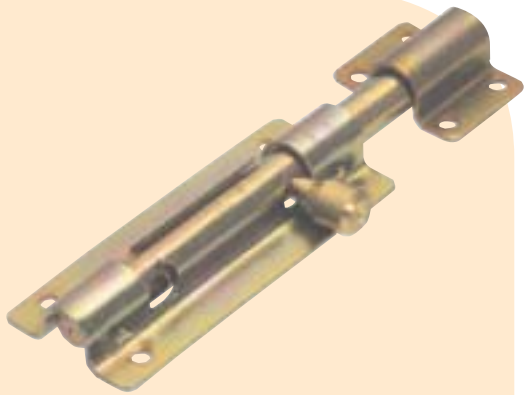

Catenaccio ad avvitare asta tonda con portalucchetto

-  Barrel bolt for padlock heavy duty to be screwed
-  Riegel zum schrauber fuer Vorhaengeschoß
-  Verrou rond à visser avec porte cadenas modèle lourd
-  Cerrojo a atornillar con barra redonda para candado





ARTICOLO - ARTICLE		L			€
Riferimento-Reference			N°	kg	x1
111/150	AT 40 15 12	150	10	2.2	2,90
111/200	AT 40 20 12	200	10	2.7	3,00

Catenaccio a saldare asta tonda

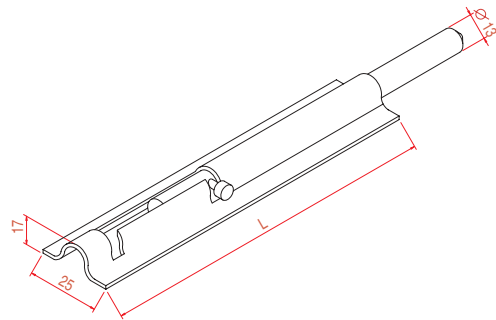
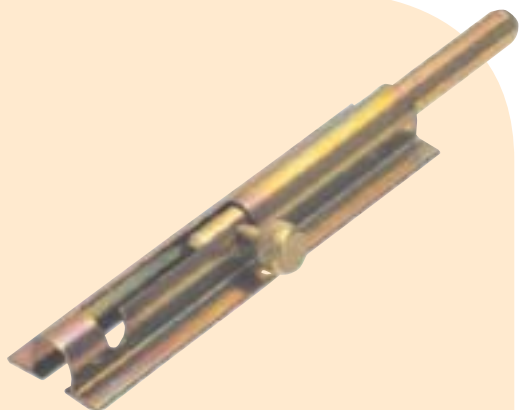
-  Barrel bolt with staple on request to be welded
-  Riegel zum schweissen mit Endschuh auf Anfrage
-  Verrou rond à souder avec gache sur demande
-  Cerrojo a soldar con barra pesada



ARTICOLO - ARTICLE		L			€
Riferimento-Reference			N°	kg	x1
112/150	AT 25 15 13	150	10	4.6	2,40
112/200	AT 25 20 13	200	10	5.6	2,90
112/250	AT 25 25 13	250	10	5.9	3,00
112/300	AT 25 30 13	300	10	7.1	3,70
112/400	AT 25 40 13	400	10	7.6	3,90
112/500	AT 25 50 13	500	10	8.8	4,60

Cerniere·Catenacci

Catenaccio verticale ad avvitare asta tonda con incontro a richiesta

- Vertical barrel bolt to be screwed with staple on request
- Vertikal Riegel zum einschrauben mit Endschuh auf Anfrage
- Verrou rond vertical avec gache sur demande à visser
- Cerrojo vertical a atornillar con barra redonda

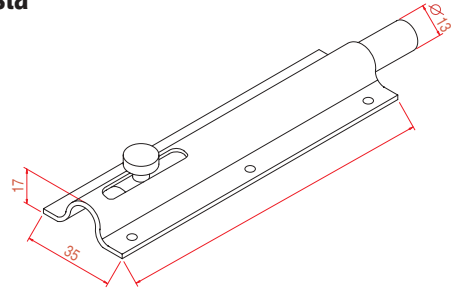

ARTICOLO - ARTICLE		L	N°		€
Riferimento-Reference			N°	EN	x1
113/150	AT 35 15 13	150	15	5.3	2,70
113/200	AT 35 20 13	200	15	6.4	3,30
113/250	AT 35 25 13	250	15	6.8	3,50
113/300	AT 35 30 13	300	15	8.3	4,30
113/400	AT 35 40 13	400	15	9.0	4,60
113/500	AT 35 50 13	500	15	10.1	5,20

Catenaccio a traverso ad avvitare rinforzato compreso di incontro

- Reinforced crossed bolt with staple to be screwed
- Verstärkert. kreuz. Riegel zum einschrauben mit Endschuh
- Verrou renforcé à visser avec gache horizontal
- Cerrojo horizontal reforzado con gancho a atornillar

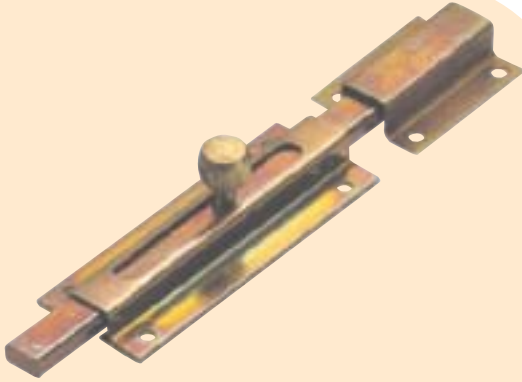
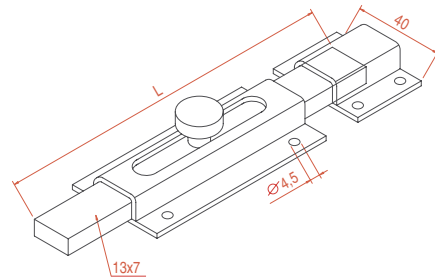

ARTICOLO - ARTICLE		L	N°		€
Riferimento-Reference			N°	EN	x1
114/80	AT 40 80 13	80	10	1.2	2,40
114/120	AT 40 12 13	120	10	1.8	2,70
114/160	AT 40 16 13	160	10	2.2	3,00
114/200	AT 40 20 13	200	10	2.7	3,30



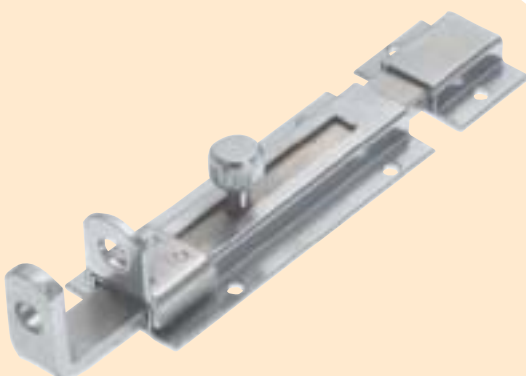
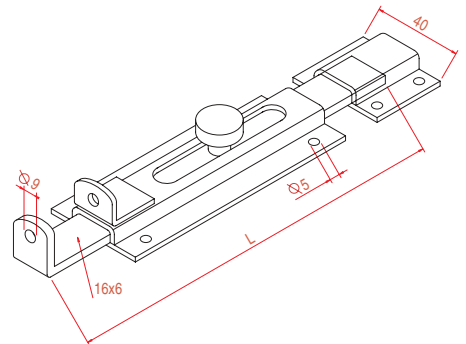

Catenaccio di traverso ad avvitare leggero compreso di incontro e portalucchetto

- Light crossed bolt with staple for padlock to be screwed
- Leicht. kreuz. Riegel zum einschrauben mit Endschuh fuer Vorhaengeschoß
- Verrou transversal léger à visser avec gache et porte cadenas
- Cerrojo horizontal liviano con gancho para candado a atornillar





ARTICOLO - ARTICLE		L	N°		€
Riferimento-Reference			N°	EN	x1
115/100	AZ 40 10 16	100	10	2	2,20
115/150	AZ 40 15 16	150	10	2.7	2,70
115/180	AZ 40 18 16	180	10	3	3,20
115/230	AZ 40 23 16	230	10	3.6	4,00



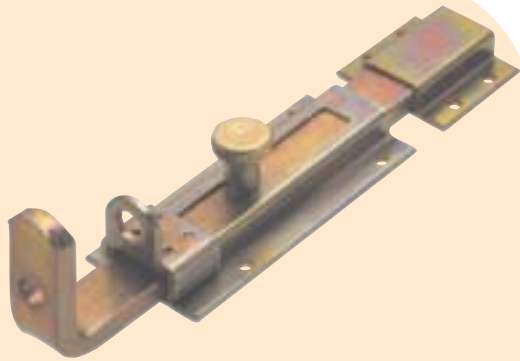
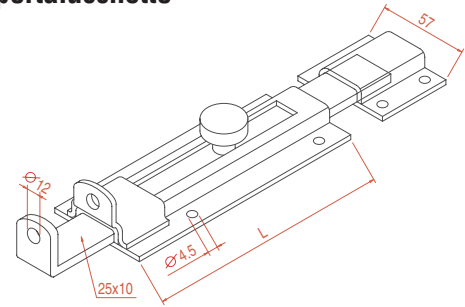

Catenaccio di traverso ad avvitare pesante compreso di incontro e portalucchetto

-  Heavy crossed bolt with staple for padlock to be screwed
-  Schwer kreuz. Riegel zum einschrauben mit Endschuh fuer Vorhaengeschoos
-  Verrou transversal lourd à visser avec gache et porte cadenas
-  Cerrojo horizontal a atornillar pesado con gancho para candado





ARTICOLO - ARTICLE		L			€
Riferimento-Reference			N°		x1
116/200	AT 57 20 25	200	5	4.2	8,50
116/300	AT 57 30 25	300	5	6.3	10,80
116/400	AT 57 40 25	400	5	8.40	12,40



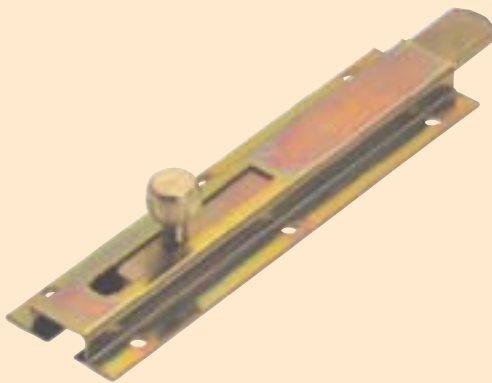
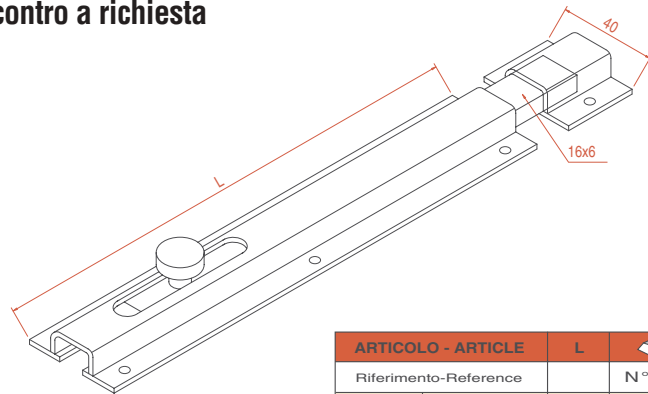

Catenaccio verticale ad avvitare leggero con incontro a richiesta

-  Light vertical bolt to be welded with staple on request
-  Leicht vertikal Riegel zum einschrauben mit Endschuh Auf anfrage
-  Verrou vertical léger à visser avec gache sur demande
-  Cerrojo vertical a atornillar liviano con gancho sobre pedido





ARTICOLO - ARTICLE		L			€
Riferimento-Reference			N°		x1
117/150	AT 40 15 16	150	10	2.3	2,90
117/200	AT 40 20 16	200	10	3	3,10
117/250	AT 40 25 16	250	10	3.7	3,40
117/300	AT 40 30 16	300	10	4.3	4,00
117/400	AT 40 40 16	400	10	5.8	5,30
117/500	AT 40 50 16	500	10	7.1	6,70

Catenaccio verticale ad avvitare pesante con incontro a richiesta

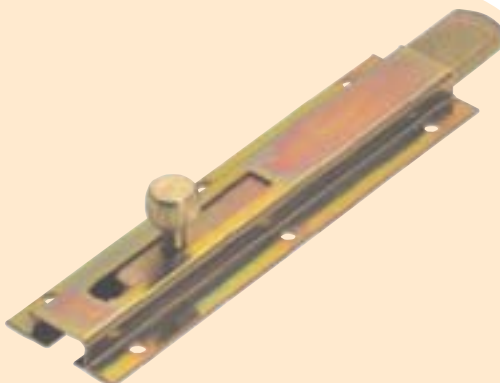
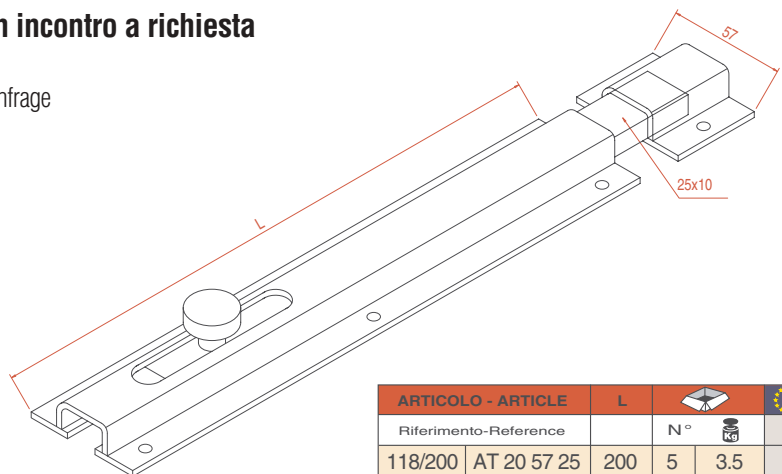



-  Heavy vertical bolt to be welded with staple on request
-  Schwer. vertikal. Riegel zum einschrauben mit Endschuh auf Anfrage
-  Verrou vertical lourd à visser avec gache sur demande
-  Cerrojo vertical pesado a atornillar con gancho sobre pedido





ARTICOLO - ARTICLE		L			€
Riferimento-Reference			N°		x1
118/200	AT 20 57 25	200	5	3.5	9,40
118/250	AT 25 57 25	250	5	4.3	10,70
118/300	AT 30 57 25	300	5	5.2	12,00
118/400	AT 40 57 25	400	5	6.9	14,40
118/500	AT 50 57 25	500	5	8.6	17,20

Cerniere·Catenacci



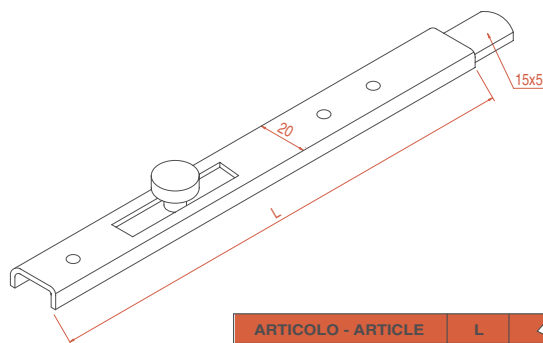

Catenaccio ad avvitare leggero con incontro a richiesta

-  Light bolt to be welded with staple on request
-  Leicht. Riegel zum einschrauben mit Endschuh auf Anfrage
-  Verrou léger à visser avec gache sur demande
-  Cerrojo liviano a atornillar





ARTICOLO - ARTICLE		L			€
Riferimento-Reference			N°		x1
119/150	AZ 20 15 15	150	15	2.2	2,30
119/200	AZ 20 20 16	200	15	2.9	2,60
119/250	AZ 20 25 15	250	15	3.4	2,90
119/300	AZ 20 30 15	300	15	4.5	3,20
119/400	AZ 20 40 15	400	15	5.3	3,80
119/500	AZ 20 50 15	500	15	7.5	4,50
119/600	AZ 20 60 15	600	15	9.2	5,00
119/800	AZ 20 80 15	800	15	12.6	6,20



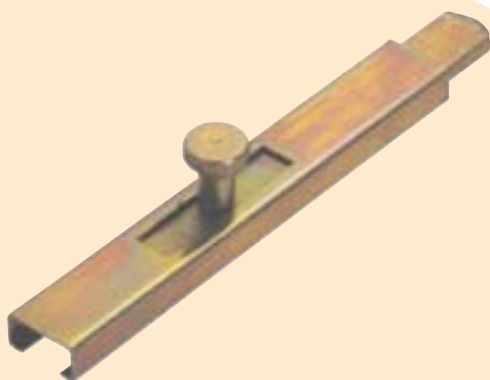
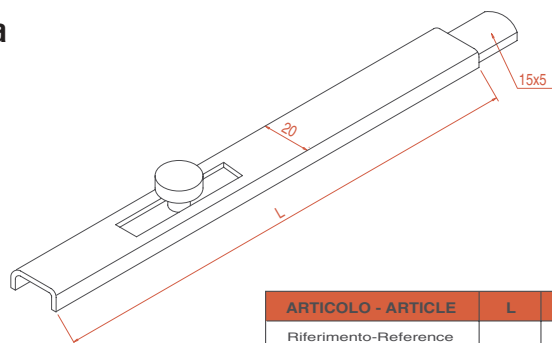

Catenaccio a saldare leggero con incontro a richiesta

-  Light bolt to be welded with staple on request
-  Leicht. Riegel zum schweissen mit Endschuh auf Anfrage
-  Verrou léger à souder avec gache sur demande
-  Cerrojo liviano a soldar





ARTICOLO - ARTICLE		L			€
Riferimento-Reference			N°		x1
120/150	AT 20 15 OS	150	15	2.6	1,90
120/200	AT 20 20 OS	200	15	3.5	2,10
120/250	AT 20 25 OS	250	15	4.3	2,30
120/300	AT 20 30 OS	300	15	5.1	2,60
120/400	AT 20 40 OS	400	15	6.8	3,00
120/500	AT 20 50 OS	500	15	8.4	3,10
120/600	AT 20 60 OS	600	15	9.6	3,60
120/800	AT 20 80 OS	800	15	12.7	4,20



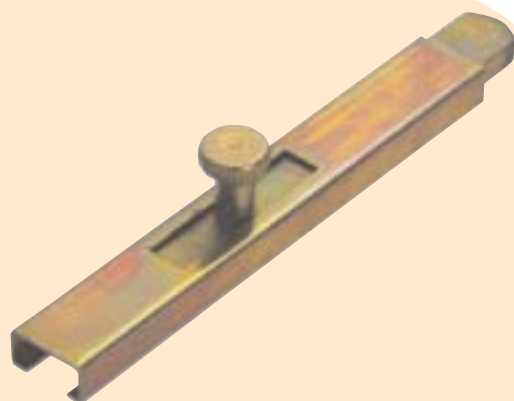
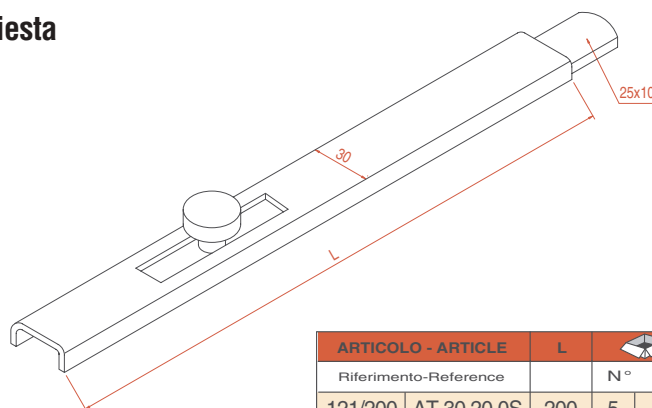

Catenaccio a saldare pesante con incontro a richiesta

-  Light bolt to be screwed with staple on request
-  Leicht. Riegel zum einschrauben mit Endschuh auf Anfrage
-  Verrou léger à visser avec gache sur demande
-  Cerrojo pesado a soldar





ARTICOLO - ARTICLE		L			€
Riferimento-Reference			N°		x1
121/200	AT 30 20 OS	200	5	2.8	4,40
121/250	AT 30 25 OS	250	5	3.4	4,60
121/300	AT 30 30 OS	300	5	4.1	5,80
121/400	AT 30 40 OS	400	5	5.3	7,00
121/500	AT 30 50 OS	500	5	6.7	8,40
121/600	AT 30 60 OS	600	5	8.0	9,80
121/800	AT 30 80 OS	800	5	10.7	12,90



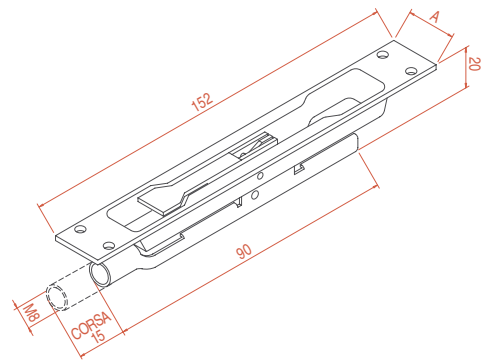

Catenaccio a leva per serramenti in metallo ad azione singola

-  Single action flush bolt for metal doors
-  Hebel Riegel fuer Metall-Tuer einz. Bewegung
-  Verrou à levier pour portes métal un mouvement
-  Cerrojo a palanca para puertas metálicas (maniobra simple)





ARTICOLO - ARTICLE		A			€
Riferimento-Reference			N°		x1
122/16	AZ 16 15 1A	16	10	1.1	2,40
122/20	AZ 20 15 1A	20	10	1.1	2,40
122/24	AZ 24 15 1A	24	10	1.2	2,40



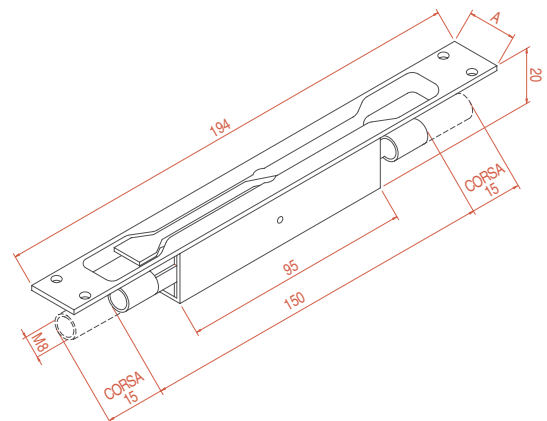

Catenaccio a leva per serramenti in metallo a doppia azione

-  Double action flush bolt for metal doors
-  Zwei-Bewegung. Hebel Riegel fuer Metall-Tuer
-  Verrou à levier pour portes metal double mouvement
-  Cerrojo a palanca para puertas metálicas (maniobra doble)





ARTICOLO - ARTICLE		A			€
Riferimento-Reference			N°		x1
123/24	AZ 24 19 2A	24	10	3	6,20

Catenaccio a leva in ottone per serramenti in metallo ad azione singola

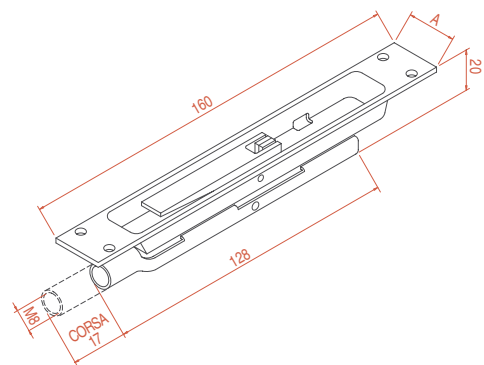



-  Single action brass flush bolt for metal doors
-  Messing Hebel Riegel fuer Metall-Tuer einz. Bewegung
-  Verrou à levier laiton pour portes metal un mouvement
-  Cerrojo a palanca en bronce para puertas metálicas (maniobra simple)







ARTICOLO - ARTICLE		A			€
Riferimento-Reference			N°		x1
124/20	AZ 20 16 00	20	10	1.6	3,90
124/24	AZ 24 16 00	24	10	1.6	3,90

Cerniere·Catenacci

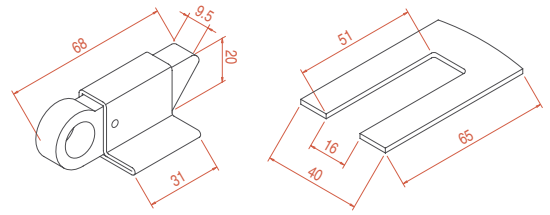
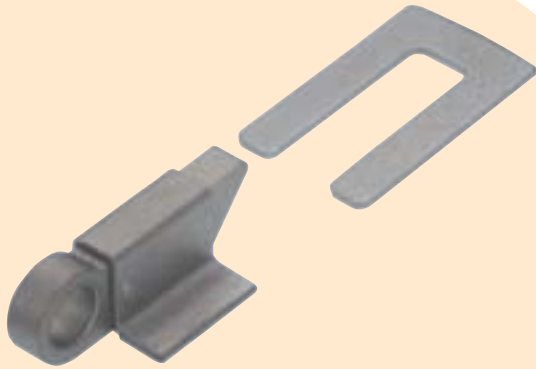



Cricchetto con piastrina

-  Plate for catch
-  Platte fuer Sperrklinke
-  Plaque pour loqueteau
-  Plaquetta con gancho







ARTICOLO - ARTICLE					
Riferimento-Reference		N°		x1	
125	AG 68 20 00	25	2.5	1,30	

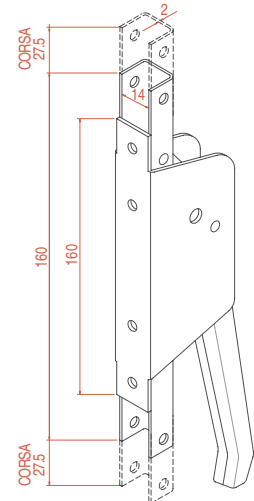



Cremonese a leva a doppia azione per serramento in acciaio zincato

-  Double action flush bolt for galvanized steel doors
-  Hebel Riegel fuer verzinkte Stahl Tuere zwei Bewegungen
-  Verrou à levier double mouvement pour portes acier galvanisé
-  Cerrojo a palanca para puertas metálicas (maniobra doble) en acero galvanizado







ARTICOLO - ARTICLE					
Riferimento-Reference		N°		x1	
127	AZ 20 16 14	5	4.0	9,40	

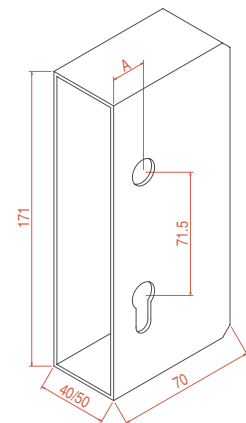



Scatola copriserratura a gancio zincata

-  Galvanized lock cover box with hook
-  Verzinkt. Schlosdeckelschachtel mit Haken
-  Boite couvercle serrure galvanisée avec crochet
-  Caja cubrecerradura con gancho galvanizado



ARTICOLO - ARTICLE		PER TUBOLARE	A				
Riferimento-Reference				N°		x1	
128/1	AZ 50 10 00	50	10	6	3.5	4,60	
128/2	AZ 40 20 00	40	20	6	3.5	4,60	



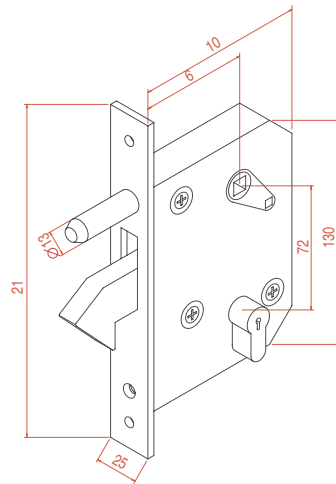

Serratura a gancio zincata

-  Galvanized for hook lock
-  Verzinkt fuer Haken-Schloss
-  Serrure à crochet galvanisée
-  Cerradura con gancho galvanizado





ARTICOLO - ARTICLE					
Riferimento-Reference		N°		x1	
129	AZ 25 21 00	1	1.3	27,30	



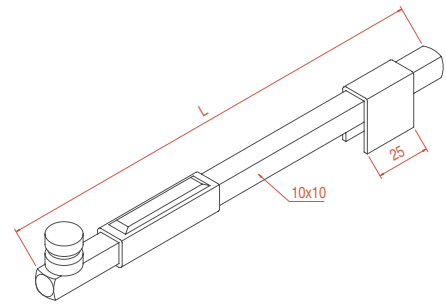
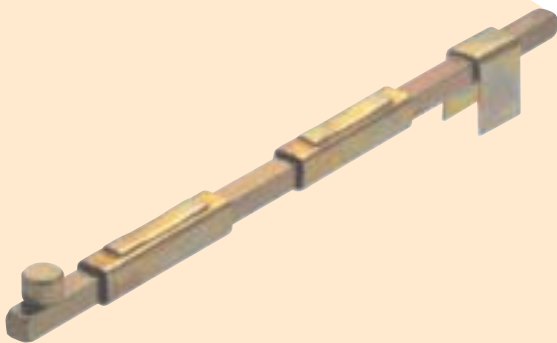

Paletto quadro leggero a saldare tropicalizzato

-  Yellow galvanized light square stake to be welded
-  Gelbverzinkt. leicht quadrat. Anschlag zum schweißen
-  Verrou carré léger à souder bichromaté
-  Cerrojo cuadrado liviano a soldar tropicalizado





ARTICOLO - ARTICLE		L				
Riferimento-Reference		N°		x1		
140/130	AT 13 10 00	130	15	1.6	3,10	
140/300	AT 30 10 00	300	15	2.6	4,20	
140/500	AT 50 10 00	500	15	5.0	5,80	



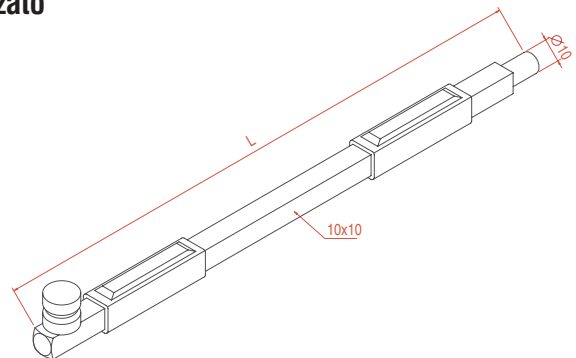

Paletto quadro leggero a saldare a punta rotonda tropicalizzato

-  Yellow galvanized light square stake with rounded top to be welded
-  Abgerundet. gelbverzinkt. leicht quadrat. Anschlag zum schweißen
-  Verrou léger carré pointe arrondie à souder bichromaté
-  Cerrojo cuadrado liviano a soldar con punta redonda tropicalizado





ARTICOLO - ARTICLE		L				
Riferimento-Reference		N°		x1		
141/130	AT 13 10 10	130	15	1.6	3,30	
141/300	AT 30 10 10	300	15	2.6	4,50	
141/500	AT 50 10 10	500	15	5.0	6,10	



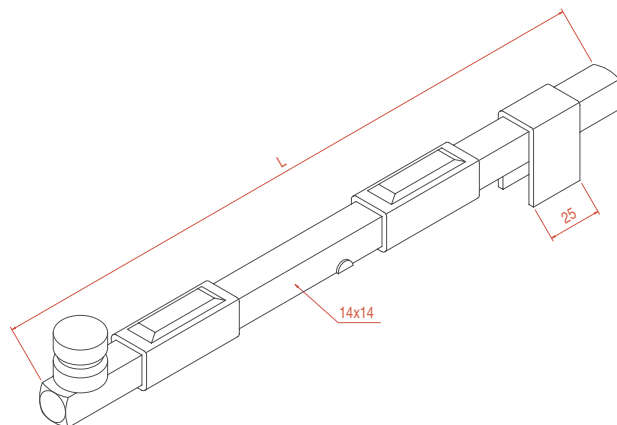
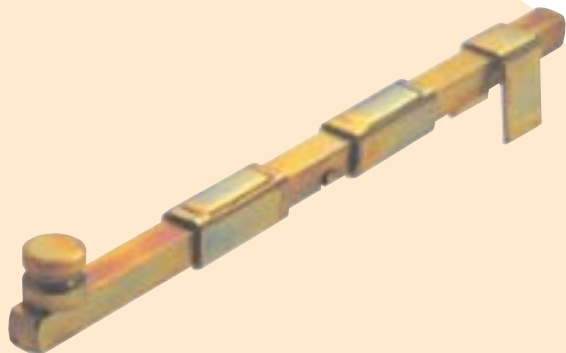

Paletto quadro pesante a saldare tropicalizzato

-  Yellow galvanized heavy square stake to be welded
-  Gelb. verzinkt. schwer. quadrat. Anschlag zum schweißen
-  Verrou carré lourd à souder bichromaté
-  Cerrojo cuadrado pesado a soldar tropicalizado





ARTICOLO - ARTICLE		L		
Riferimento-Reference			N°	x1
142/330	AT 33 14 00	330	10	11.5
142/600	AT 60 14 00	600	10	12.0



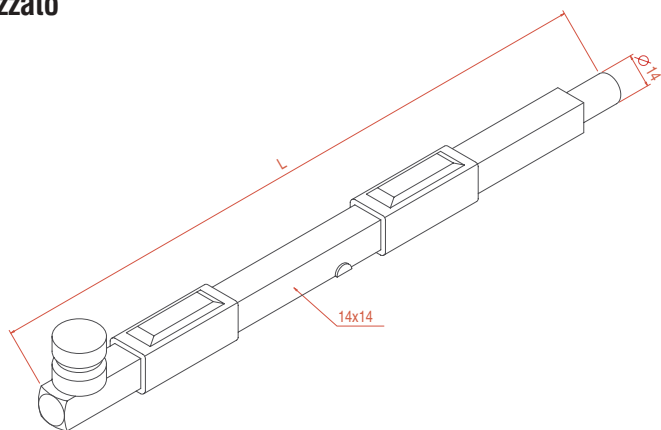
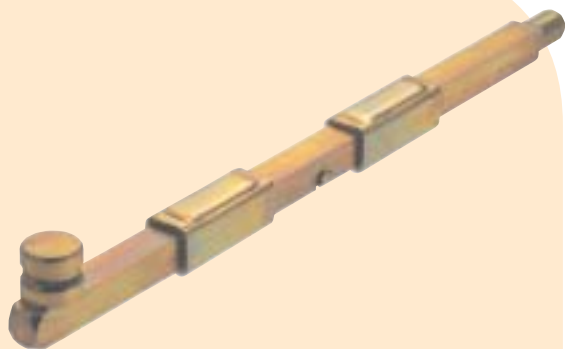

Paletto quadro pesante a saldare a punta rotonda tropicalizzato

-  Yellow galvanized heavy square stake with rounded top to be welded
-  Abgerundet. gelb. verzinkt. schwer. quadrat. Anschlag zum schweißen
-  Verrou lourd carré pointe arrondie à souder bichromaté
-  Cerrojo cuadrado pesado a soldar con punta redonda tropicalizado



ARTICOLO - ARTICLE		L		
Riferimento-Reference			N°	x1
143/330	AT 33 14 14	330	10	7.2
143/600	AT 60 14 14	600	10	12.0

Paletto di bloccaggio tropicalizzato per cancelli ad ante motorizzati

-  Blocking stake for automated gates
-  Torendanschlag mit Federauffangung
-  Verrou autobloquant pour portail à battants motorisés
-  Cerrojo autoblocante para cancelas motorizadas 2 hojas

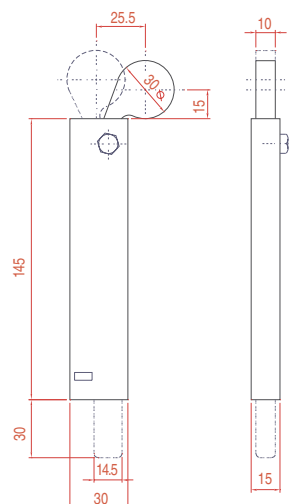

ARTICOLO - ARTICLE			
Riferimento-Reference		N°	x1
56	FT 30 15 00	20	9.5

Cardini

-  Hinges
-  Torbänder
-  Gonds
-  Pernios





pag.6-18

Cerniere·Catenacci

-  Hinges - Bolts
-  Scharniere - Riegel
-  Charnières - Verrous
-  Bisagras - Cerrojos

pag.19-29

Ruote cremagliere e guide

-  Wheels/racks/guides
-  Laufrollen/Schienen
-  Roues/Crémaillères/rails
-  Ruedas, cremalleras y guías

pag.30-52

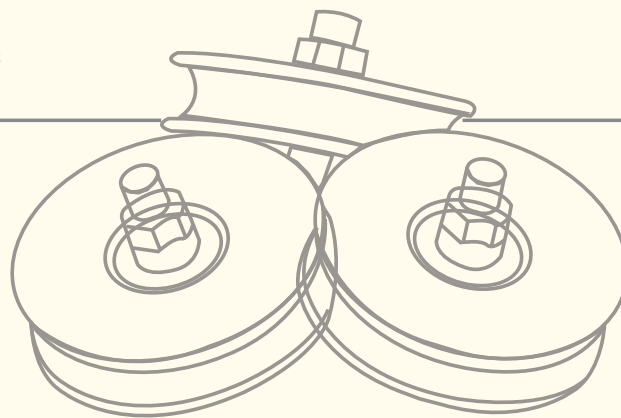





Piastre e rulli guida

-  Rollers guide
-  Führungsrollen
-  Plots de guidage
-  Placas y Rodillos





pag.53-57

Accessori per portoni·Cuscinetti

-  Accessories for sliding and folding doors and bearings
-  Zubehör fuer falt-und Schiebetore, Lagern
-  Accessoires pour portes coulissantes et accordéon
-  Accesorios para puertas correderas y plegables

pag.58-93

Carrelli autoportanti

-  Cantilever gate carriages
-  Wagen fuer freitragende Schiebetore
-  Chariots pour portail autoportants
-  Carros para cancelas autoportantes

pag.94-97